



# SMBC RAIL SERVICES

# 6500C

## Center Flow<sup>®</sup> Car



The Center Flow<sup>®</sup> covered hopper car is the original stub sill design covered hopper car. The car has evolved through the years and undergone many improvements and refinements while still maintaining its reputation as the highest quality covered hopper car in the industry. Versatility has always been the basis of the car itself and the Center Flow<sup>®</sup> product line, which is designed to handle the complete spectrum of dry bulk products. The Model 6500 Center Flow<sup>®</sup> covered hopper car is specifically designed to transport low density commodities, up to 32 lbs./ft.<sup>3</sup>. The car can be equipped with any series of loading hatches and discharge outlets depending upon your handling requirements. In addition, the car can be built for a gross rail loading of either 263,000 lbs. or 286,000 lbs. For your application and troubleshooting needs, the Center Flow<sup>®</sup> covered hopper car has the complete backing of the SMBC Rail Services staff. With over 140,000 cars built to date, the Center Flow<sup>®</sup> covered hopper car has the proven service history that is so critical for today's transportation.

# CENTER FLOW® Accessories

## SPECIFICATIONS

Cubic Capacity .....	6500 ft <sup>3</sup>
Center of Gravity from Rail	
empty .....	64.5"
loaded .....	95.5"
Horizontal Curve Negotiability, uncoupled (minimum radius of curvature) .....	180'
Vertical Curve Negotiability, uncoupled, empty .....	1172'
Number of Discharge openings .....	4
Length Over Strikers .....	65' 8"
Length Over Coupler Pulling Face (Solid) .....	67' 8"
Extreme Height .....	15' 6"
Extreme Width .....	10' 8"
Estimated Light Weight - Complete (includes standard outlet and hatch arrangement) .....	66,000 lbs
Plate C Construction	

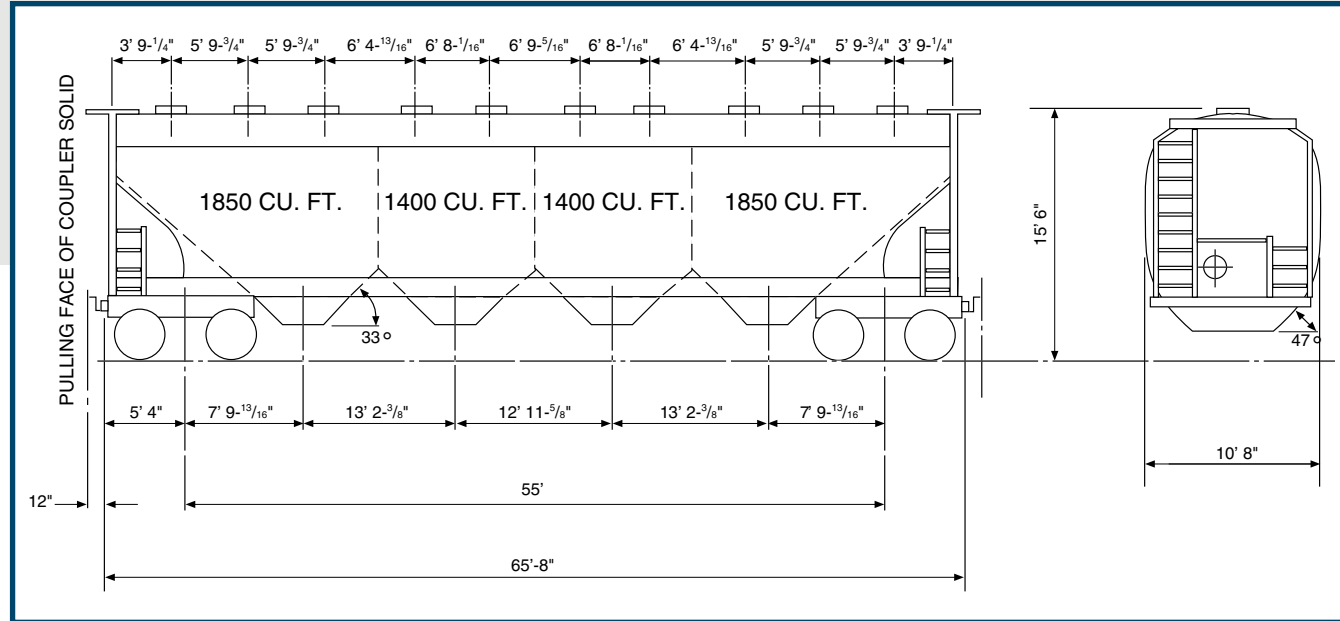

## LOADING HATCHES

The standard 6500C CENTER FLOW® car is equipped with ten 20" diameter round single strap hatches which are preferred for loading most general service commodities. If desired, alternate types of hatches are available to adapt to your specific loading system or product.

### ALTERNATES:

- 20" diameter round hatches (10) - nylon
- 30" diameter round hatches (8) - fiberglass
- Elongated hatches (4) - fiberglass
- Continuous hatch (1) - fiberglass

## UNLOADING SYSTEM

There is a CENTER FLOW® unloading system specifically tailored to your lading type or unloading facility. They range from the standard controlled gravity gates for general service to ultra-sanitary outlets for products extremely sensitive to contamination. Specialty outlets are also available for hard to handle powders and sparger/solution type systems.

### ALTERNATES:

- Gravity Outlets (4)
- Gravity-Pneumatic Outlets (4)
- Adjustable Pneumatic Outlets (4)
- Fluidized Adjustable Pneumatic Outlets (4)
- Fluidized Butterfly Outlets (4)
- Sparger Outlets (4)
- Vibrator Brackets (2/hopper, 8/car)