



SMBC RAIL SERVICES

4650C Center Flow® Car



The Center Flow® covered hopper car is the original stub sill design covered hopper car. The car has evolved through the years and undergone many improvements and refinements while still maintaining its reputation as the highest quality covered hopper car in the industry. Versatility has always been the basis of the car itself and the Center Flow® product line, which is designed to handle the complete spectrum of dry bulk products. The Model 4650C Center Flow® covered hopper car is specifically designed to transport medium density commodities, up to 43 lbs./ft.³ The car can be equipped with any series of loading hatches and discharge outlets depending upon your handling requirements. In addition, the car can be built for a gross rail loading of either 263,000 lbs. or 286,000 lbs. For your application and troubleshooting needs, the Center Flow® covered hopper car has the complete backing of the SMBC Rail Services staff. With over 100,000 cars built to date, the Center Flow® covered hopper car has the proven service history that is so critical for today's transportation.

CENTER FLOW® Accessories

SPECIFICATIONS

Cubic Capacity	4650 ft ³
Center of Gravity from Rail	
empty	61.6"
loaded	97.4"
Horizontal Curve Negotiability, uncoupled (minimum radius of curvature)	150'
Vertical Curve Negotiability, uncoupled	371'
Number of Discharge openings	3
Length Over Strikers	51' 11"
Length Over Coupler Pulling Face (Solid)	53' 11"
Extreme Height	15' 5-1/8"
Extreme Width	10' 8"
Estimated Light Weight - Complete (includes standard outlet & hatch arrangement)	62,000
Plate C Construction	

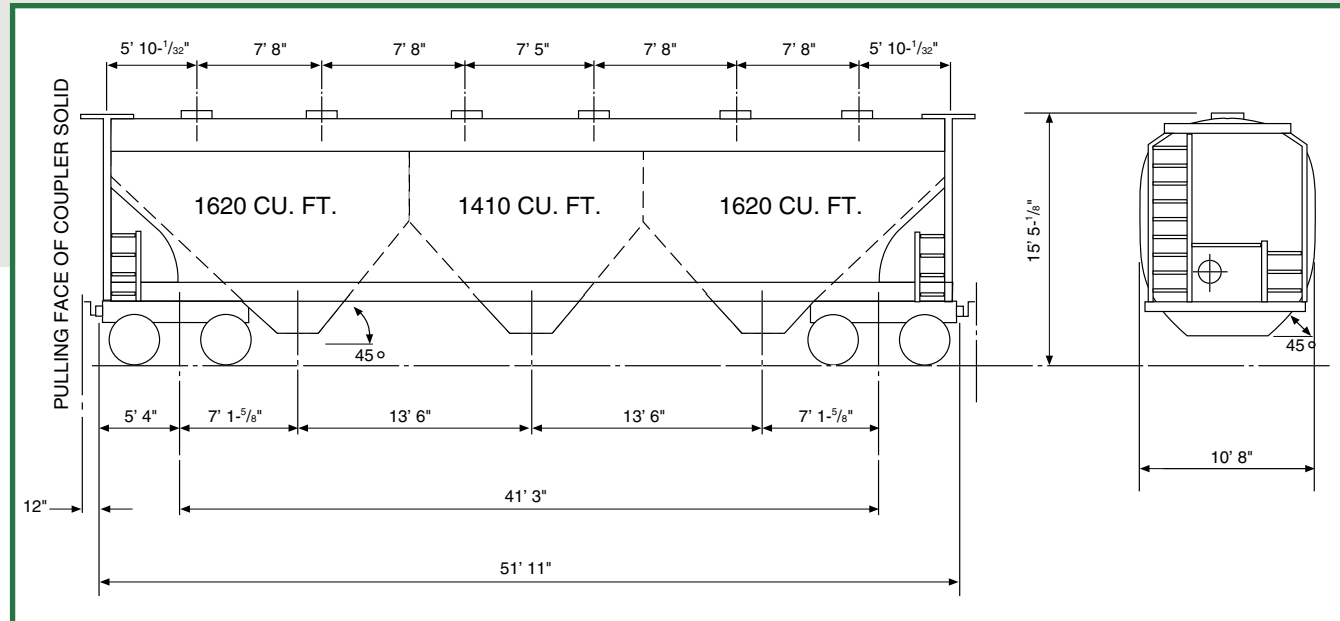

LOADING HATCHES

The standard 4650C CENTER FLOW® car is equipped with six 30" diameter round steel hatches. This is the hatch of choice for this size car and is suitable for loading a wide range of general service commodities. If desired, alternate types of hatches are available to adapt to your specific loading system or product.

ALTERNATES:

- 20" diameter round hatches (6) - nylon
- 30" diameter round hatches (6) - fiberglass
- Elongated hatches (3) - fiberglass
- Continuous hatch (1) - fiberglass

UNLOADING SYSTEM

There is a CENTER FLOW® unloading system specifically tailored to your lading type or unloading facility. They range from the standard controlled gravity gates for general service to ultra-sanitary outlets for products extremely sensitive to contamination. Specialty outlets are also available for hard to handle powders and sparger/solution type systems.

ALTERNATES:

- Gravity Outlets (3)
- Gravity-Pneumatic Outlets (3)
- Adjustable Pneumatic Outlets (3)
- Fluidized Adjustable Pneumatic Outlets (3)
- Fluidized Butterfly Outlets (3)
- Sparger Outlets (3)
- Vibrator Brackets (2/hopper, 6/car)